

>>> Service Letter

Technical Aspects are FAA Approved

Number: L01-12 A
Replaces ServL101-012

Date: 07/12/2004

Subject: Overhaul and repair of Superior Propeller Governor Adapter

Application:

Propeller Governor Adapter	ENGINE APPLICATIONS
SL75545 SL78594	Refer to Superior Service Letter No. L01-11, Latest Revision

Compliance: At any time the Propeller Governor Adapter Assembly is removed for overhaul or repair.

Propeller Governor Adapter Assembly:

The Superior Propeller Governor Adapter Body is precision machined from AA 2024-T4 or 6061-T6 aluminum alloy bar stock. The studs, helical coils and pipe plug are PMA or MS parts.

Inspection:

Remove the 1/8 – 27 pipe plug and clean the oil passages. Visually inspect the .8750 - .8755 bore in the aluminum body for evidence of wear and damage. The aluminum body must be subjected to fluorescent particle inspection per AMS 2645 and accepted per mil-std-1907, grade B (or other FAA approved repair station procedure). Studs and thread inserts must be inspected for damage and replaced as necessary. Figure 1 provides dimensional limits and replacement part numbers and installation instructions.

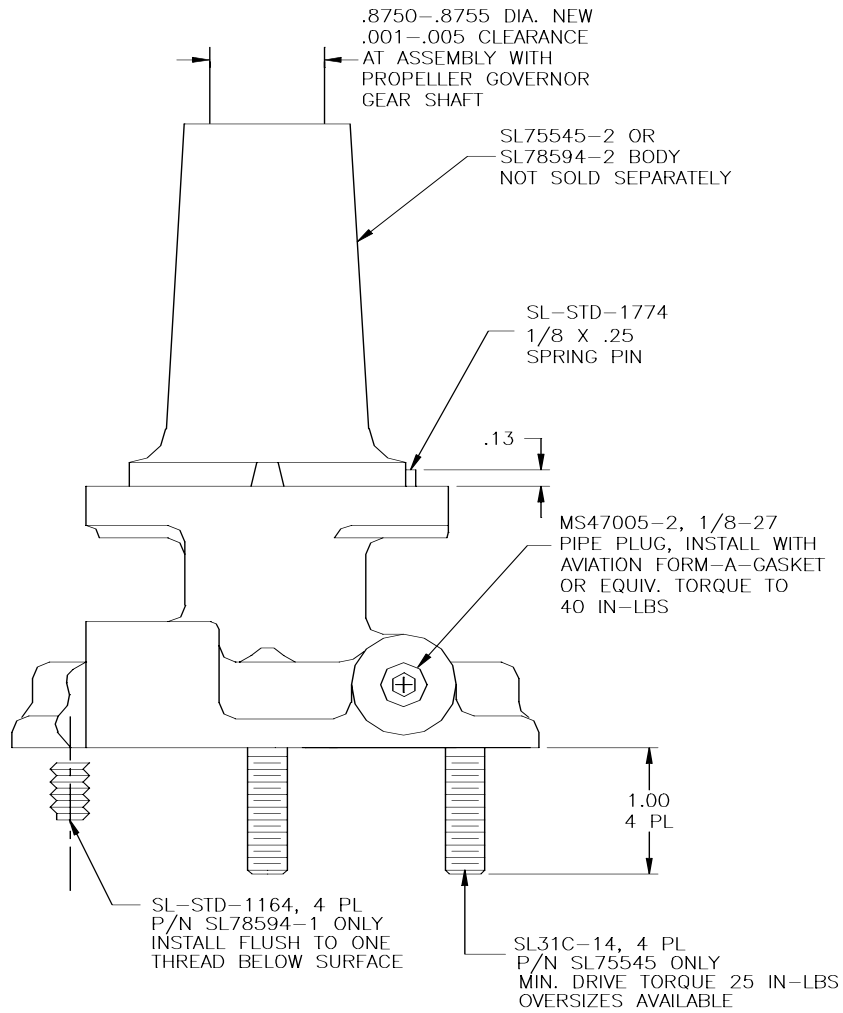

FIGURE 1
PROPELLER GOVERNOR
ADAPTER ASSEMBLY