

**>>> Service Letter**

Technical Aspects are FAA Approved

**Number: L01-10 A**

**Replaces ServL101-010**

**Date:** 07/12/2004

**Subject:** Overhaul and repair procedures for Superior Vacuum Pump Adapter Assembly.

**Application:**

Vacuum Pump Adapter	ENGINE APPLICATIONS
SL61098	Refer to Superior Service Letter No. L01-09, Latest Revision

**Compliance:** At any time the Vacuum Pump Adapter Assembly is removed for overhaul or repair.

Vacuum Pump Adapter Assembly:

The Superior Vacuum Pump Adapter Assembly is precision machined from AA 2024-T4 or 6061-T6 aluminum alloy bar stock. The oil seal and dowel are PMA parts.

Inspection:

Visually inspect the .8750 - .8755 bore in the aluminum body for evidence of wear and damage. The aluminum body must be subjected to fluorescent particle inspection per AMS 2645 and accepted per mil-std-1907, grade B (or other FAA approved repair station procedure). The oil seal must be inspected for wear or damage and replaced as necessary. Figure 1 provides dimensional limits and replacement part numbers and installation instructions.

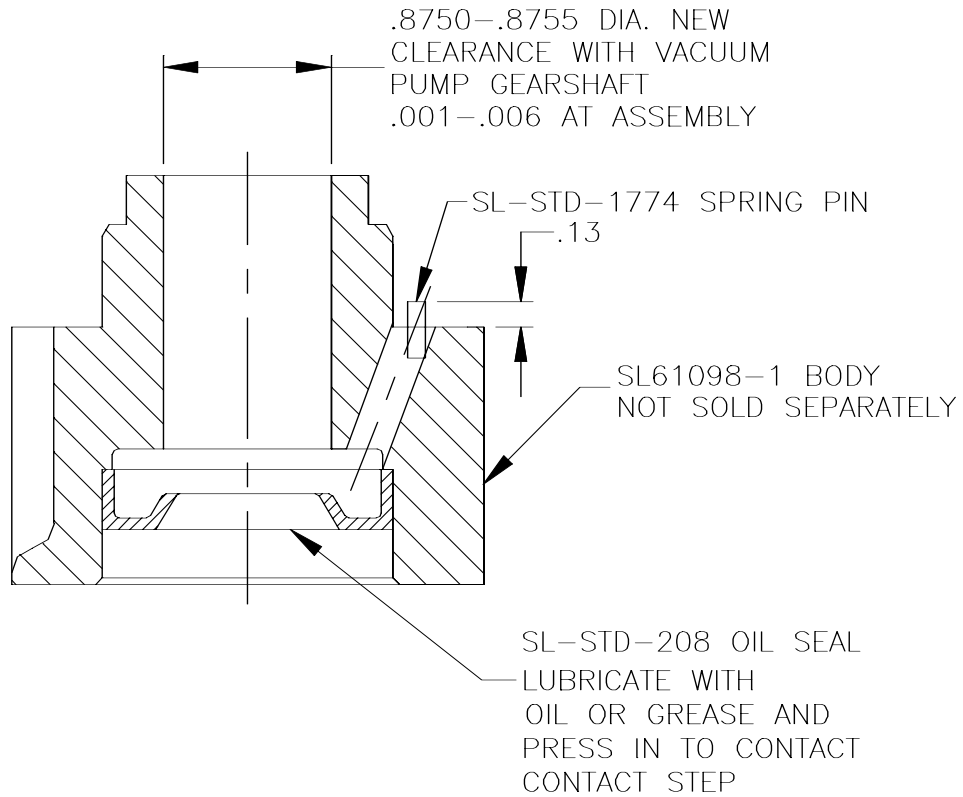

FIGURE 1  
VACUUM PUMP  
ADAPTER ASSEMBLY